

**Measuring****Positioning**

IKS23

Incremental Magnetic Sensing Head

- Linear and rotary applications
- Non-contact, quick position measurement



Features

- incremental encoder for 1-, 2- & 5-mm pole pitch
- resolution options between 0.5 μm and 50 μm
- measuring length up to 100 m / 328 ft
- IP67 protection rating
- wide mounting tolerances up to 2 mm / 0.078"



Measuring movements with IKS23: simple - precise - economic

The incremental magnetic sensing head IKS23 for linear and rotary applications is highly accurate and modular. IKS23 comes in different versions, which can be configured to customer-specific requirements. In combination with our tailor-made linear and rotary scales, we offer measurement solutions for almost every application.

Environmental Specifications

shock	250 g, 6 ms acc. to CEI EN 60068-2-27
vibrations	10 g, 5 - 2000 Hz acc. to CEI EN 60068-2-6
protection	IP67
operating temperature range	- 25 °C ÷ + 85 °C [- 13°F + 185° F]
storage temperature range	- 40°C ÷ + 100° C [- 40°F + 212 °F]

Mechanical Specifications

dimensions	see drawing
housing material	die cast aluminum, UNI EN AC-46100
electrical connection	Hi-flex cable M8 2.0 m or M12 8 pin inline plug
gap sensor/tape (without cover strip)	1 mm pole pitch -> gap 0.1 ... 0.5 mm 2 mm pole pitch-> gap 0.1 ... 1 mm 5 mm pole pitch-> gap 0.1 ... 2.5 mm
travel speed (mechanical)	max. 16 m/s
measurement length	tape length - 5 mm each side

Electrical Specifications

resolution	0.01 / 0.005 / 0.002 / 0.0005 mm
sensor accuracy	± 15 µm max.
repeat accuracy	± 1 increment
output circuits	line driver, push-pull
output signals	AB0 /AB0
counting frequency	acc. to edge distance setting push-pull: 3 MHz max. @ 24Vdc, cable 1 m line driver: 5 MHz max. @ 5Vdc, cable 1 m
power supply	+ 5 Vdc ± 5%, + 10 Vdc ÷ + 30 Vdc
power consumption	70 mA max.
protection	against inversion of polarity (except 5 Vdc version) and short-circuit
EMC	acc. to EN 61000-6-2 level 3

Accessories

LMS	magnetic tape
RMS	rotary magnetic scales
kit wipers	wipers for IKS23 (00060051)

Edge Distance Selection

order code	edge distance (µsec.)	max. counting frequency (kHz)	resolution (µm) vs. max. possible speed (m/s)																																							
			0,08					0,5					1					2					5					10					25					50				
			pole pitch																																							
1	2	5	1	2	5	1	2	5	1	2	5	1	2	5	1	2	5	1	2	5	1	2	5	1	2	5																
F5000	0,2	5000	-	-	0,4	-	-	2,5	-	-	5	-	-	10	-	-	-	-	-	-	-	-	-	-	-	-																
F3333	0,3	3333	-	-	-	1,66	-	1,67	3,33	3,33	3,33	6,66	6,66	6,66	16	-	16	20	20	25	-	-	25	-	20	25																
F2000	0,5	2000	-	-	-	1	-	1	2	2	2	4	4	4	10	-	10	20	20	20	-	-	25	-	20	25																
F1000	1	1000	-	-	-	0,5	-	-	1	1	1	2	2	2	5	-	5	10	10	10	-	-	25	-	20	25																
F500	2	500	-	-	-	-	-	-	-	-	-	1	1	-	2,5	-	2,5	5	5	5	-	-	12,5	-	20	25																
F200	4	200	-	-	-	-	-	-	-	-	-	-	-	-	1,25	-	1,25	2,5	2,5	2,5	-	-	6,25	-	12,5	12,5																

Technical Drawing

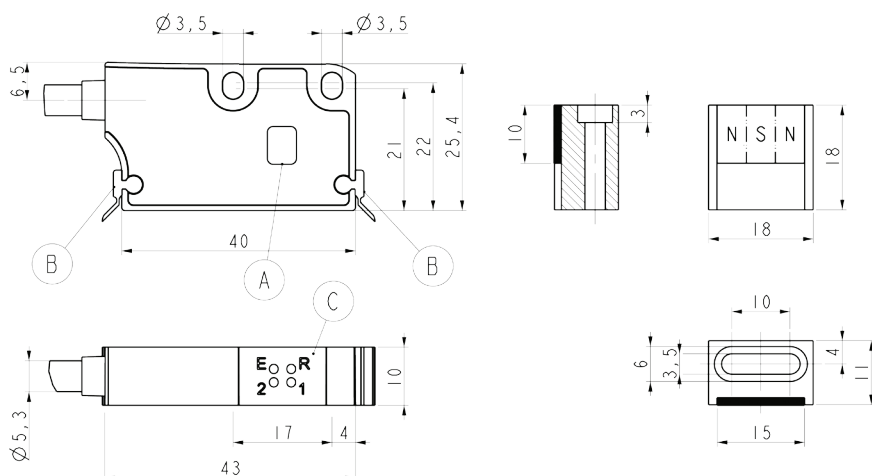

A	Reference sensor "R"
B	Dust wipers
C	Diagnostic LEDs
E	Gap/Speed error (red)
R	Reference detection (green)
1	Power ON (green)
2	Not used

Order Code Parameters

IKS23 - Z - P - V - D - R - F - T - L - C

		code	explanation
parameters	Z	reference signal	Z0 without
		Z1 periodic index signal from the pole pitch (every 1 mm, 2 mm, 5 mm)	
		Z2 unique reference signal (on request)	
	P	pole pitch	P1 1 mm
			P2 2 mm
			P5 5 mm
	V	supply voltage	V5 + 5Vdc \pm 5 %
			V24 + 10 Vdc - + 30 Vdc
	D	interface	D1 line driver (AB, /AB)
			D2 push-pull (AB)
			D3 push-pull (AB, /AB)
	R	resolution	@ 1 mm pole pitch Rx 10 = 10 μ m 5 = 5 μ m 2 = 2 μ m 1 = 1 μ m 05 = 0.5 mm
			@ 2 mm pole pitch Rx 50 = 50 μ m 10 = 10 μ m 2 = 2 μ m 1 = 1 μ m
			@ 5 mm pole pitch Rx 50 = 50 μ m 25 = 25 μ m 10 = 10 μ m 5 = 5 μ m 2 = 2 μ m 1 = 1 μ m 05 = 0.5 μ m 008 = 0.08 μ m
	F	max. output frequency	F5000 5000 kHz / 0.2 μ s (only available with P5 and D1 interface)
			F3333 3333 kHz / 0.3 μ s (only available with D1 interface)
			F2000 2000 kHz / 0.5 μ s
			F1000 1000 kHz / 1 μ s
			F500 500 kHz / 2 μ s
			F250 250 kHz / 4 μ s
	T	cable type	T1 hi-flex cable / drag chain quality
	L	cable length	L2 2 m
			Lx ... m (on request)
C	connector	C1 M12 plug (male)	
		C2 M8 plug	